

VIBRAHONE™

FCV-150ULE-2



Vibra Finish Company

WWW.VIBRAFINISH.COM

FCV-150ULE-2 Exploded View Diagram

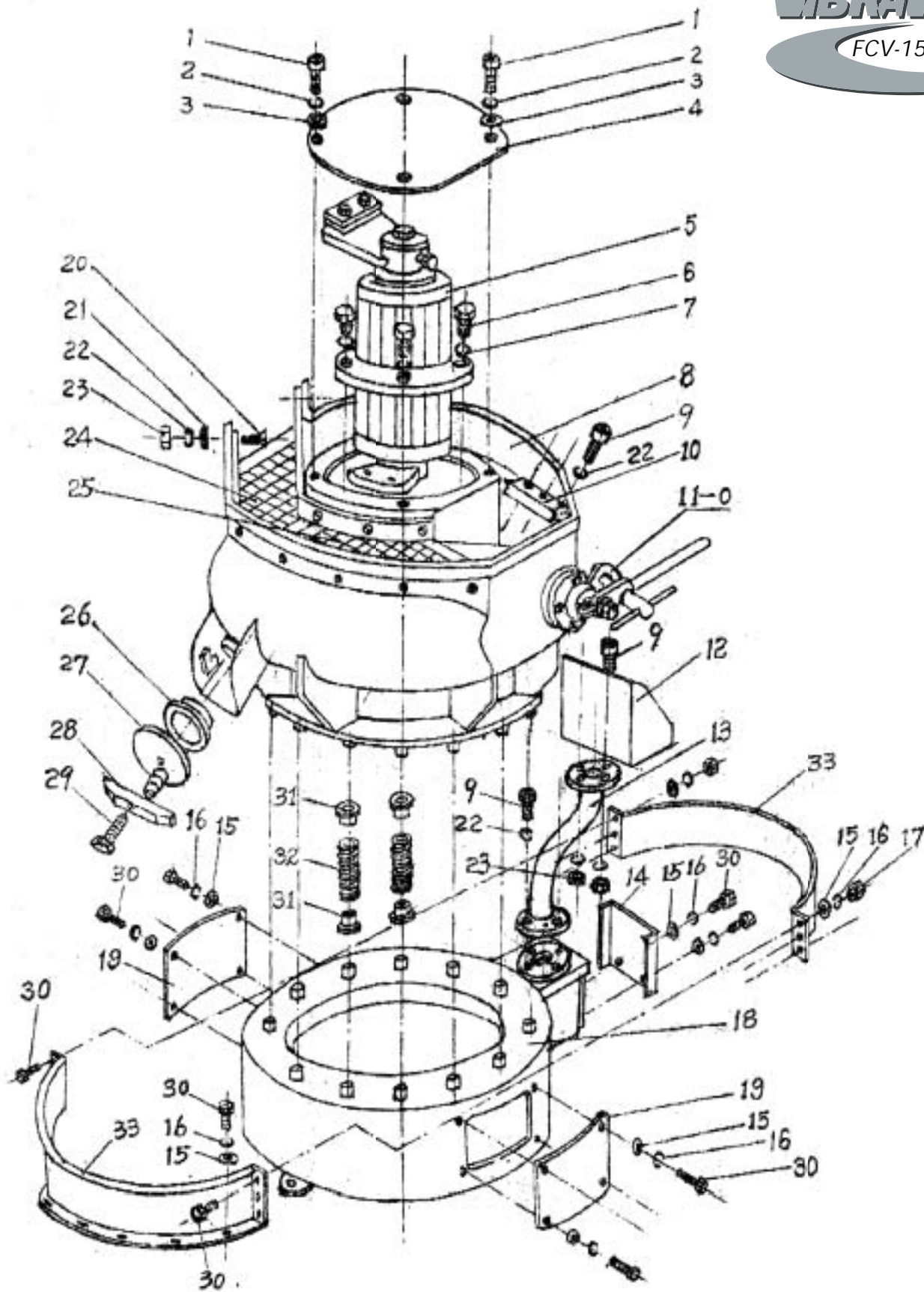

Vibra Finish Company

WWW.VIBRAFINISH.COM

FCV-150ULE-2 PRIMARY PARTS LISTING
 (refer to diagram on page 2 of 5)



ITEM	DESCRIPTION	QTY
1	HEX SOCKET HEAD CAP SCREW (M10*30)	4
2	SPRING WASHER (Ø 10)	4
3	PLAIN WASHER (Ø10)	4
4	CENTRAL COVER (Ω=5)	1
5	VIBRATORY MOTOR (1.5KW)	1
6	HEX BOLT (M20*65)	8
7	SPRING WASHER (Ø 20)	8
8	BOWL (Ø 1126 PU20)	1
9	HEX SOCKET HEAD CAP SCREW (M10*20)	10
10	CLAMP FOR DAM BLADE	1
11	DAM BLADE ASSEMBLY (SEE PG 4 DIAGRAM & LIST)	1
12	ELECTRIC BOX (306*172*280)	1
13	COLUMN OF ELECTRIC BOX (620*200)	1
14	ELECTRIC BOX COVER (174*170)	1
15	PLAIN WASHER (Ø6)	26
16	SPRING WASHER (Ø6)	26
17	NUT (M6)	6
18	BASE (Ø900)	1
19	DOOR ON BASE (Ω=1.2)	2
20	SCREW TO LOCK SCREEN (M10*45)	17
21	PLAIN WASHER (Ø10)	17
22	SPRING WASHER (Ø10)	27
23	NUT (M10)	19
24	FRONT SCREEN (14,19,25,32,40)	1
25	BACK SCREEN (14,19,25,32,40)	1
26	DRAIN BOARD (Ø126)	2
27	DRAIN COVER	2
28	DRAIN COVER LOCK	2
29	HEX LOCK SCREW (M16*1.5*50)	2
30	HEX GROOVE BOLT (M6*10)	26
31	PU PAD (Ø26)	24
32	SPRING (Ø8*48*160)	12
33	SPRING GUARD	2

FCV-150ULE-2 Inverter (not shown in these specifications)

Please refer to the *A.C. Tech Inverter Manual* for instructions on operation and maintenance of the inverter.



Vibra Finish Company

WWW.VIBRAFINISH.COM

FCV-150ULE-2—(DAM BLADE ASSY & PARTS LIST)

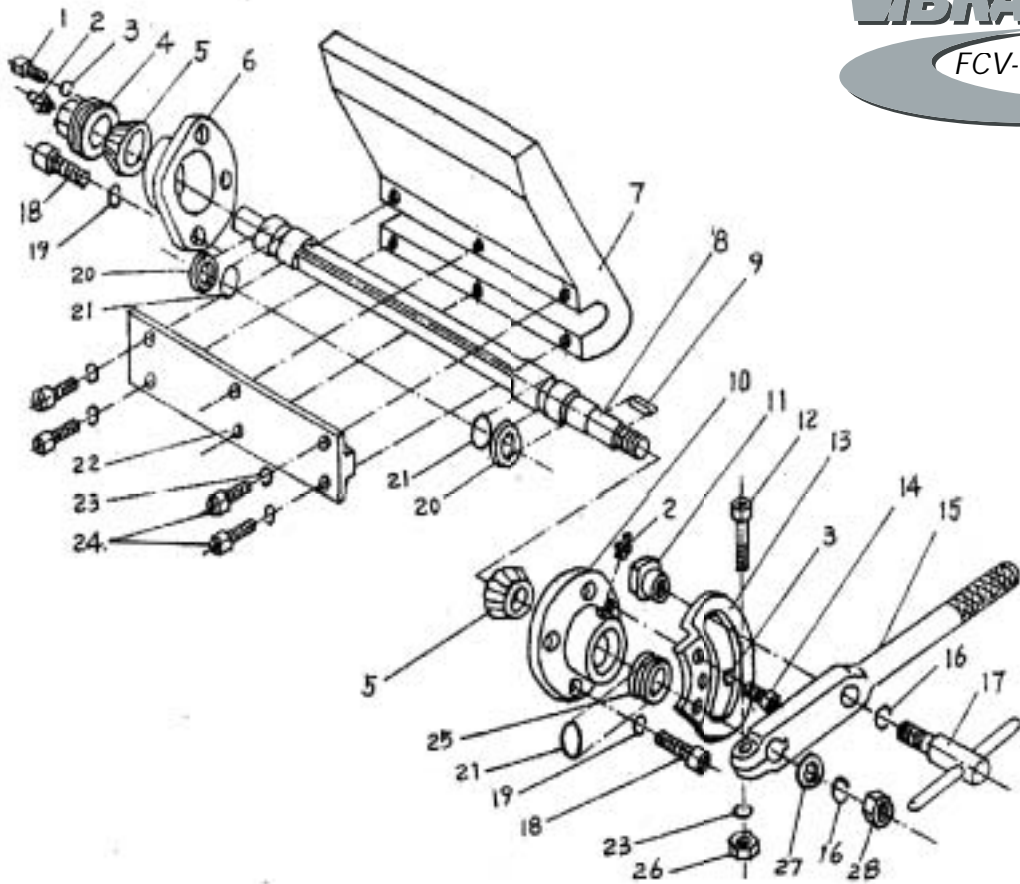

ITEM	DESCRIPTION	QTY
1	HEX SOCKET HEAD CAP SCREW (M8*15)	2
2	GREASE (M10*1)	2
3	SPRING WASHER (Ø8)	5
4	LOCK SCREW (M60*2)	1
5	CONE BEARING (7605)	2
6	INSIDE BEARING HOUSE (Ø130)	1
7	DAM BLADE (150L)	1
8	SHAFT	1
9	KEY (A8*22)	1
10	OUTSIDE BEARING HOUSE (Ø130)	1
11	LOCK SCREW (M16*1.5)	1
12	HEX SOCKET HEAD CAP SCREW (M10*40)	3
13	ARCH PLATE	1
14	HEX SOCKET HEAD CAP SCREW (M8*20)	3
15	DAM BLADE HANDLE	1
16	SPRING WASHER (Ø20)	2
17	T-LOCK	1
18	HEX SOCKET HEAD CAP SCREW (M12*35)	6
19	SPRING WASHER (Ø12)	6
20	OIL SEALING (30*50*10)	2
21	O-RING (25*3.1)	3
22	CLAMP ON DAM BLADE (300L)	1
23	SPRING WASHER (Ø10)	7
24	HEX SOCKET HEAD CAP SCREW (M10*25)	6
25	RETAINING RING (Ø35.5)	1
26	NUT (M10)	1
27	PLAIN WASHER (Ø20)	1
28	NUT (M20)	1



Vibra Finish Company

WWW.VIBRAFINISH.COM

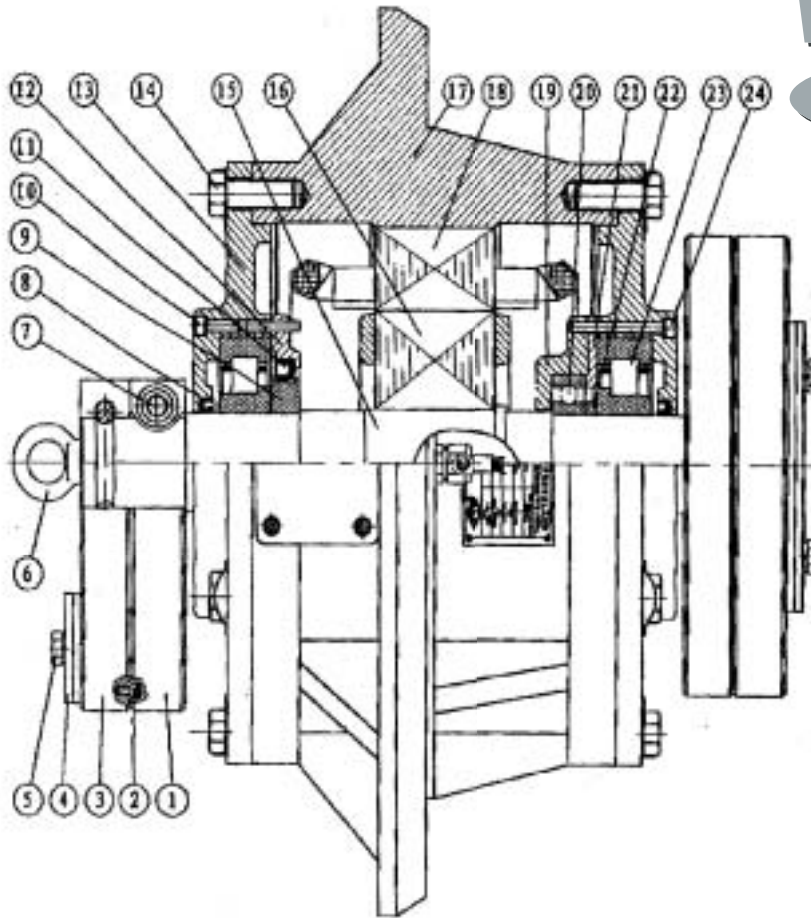

ITEM	DESCRIPTION	QTY
1	INNER EXCITATION BLOCK	1
2	ORIENTATION BOLT	1
3	OUTER EXCITATION BLOCK	1
4	ADJUSTING BLOCK	1
5	FASTEN BOLT FOR ADJUSTING BLOCK	1
6	LIFT ON BOLT	1
7	FASTEN BOLT FOR EXCITATION BLOCK	1
8	SEAL RING FOR OUTER OIL PROOF	1
9	BEARING WASHER	1
10	FASTEN BOLT FOR INNER COVER #1	1
11	SEAL RING FOR INNER OIL PROOF	1
12	INNER COVER #1 (INSIDE BEARING RET. MAIN SHAFT)	1
13	COVER	1
14	FASTEN BOLT FOR COVER	1
15	MOTOR SHAFT	1
16	CAST ALUMINUM ROTOR	1
17	STATOR FRAME	1
18	RULE STATOR	1
19	INNER COVER #2	1
20	BEARING	1
21	WASHER	1
22	RETAINER RING FOR BEARING	1
23	COLUMN BEARING	1
24	FASTEN BOLT FOR INNER COVER #2	1



Vibra Finish Company

WEST
 888 B'G'U'K U' California 9' \$*)
 Tel (8\$)) + -0033
 Fax (8\$)) + -\$\$(&
 Toll Free 800-635-0259
 www.vibrafinish.com

EAST
 84% Seward Road Hamilton, Ohio 45011
 Tel (513) 870-6300
 Fax (513) 870-6311
 Toll Free 800-253-1941
 www.vibrafinish.com